



Providing trouble free operation with fully concealed locking and sequential engagement the Encore Multi-Point Locking System is the most complete locking system for casement and awning windows. The Encore Lock brings a number of new features unique to the window industry – including an option for securing round-top windows and a built-in construction handle which allows windows to be operable prior to painting or staining. In addition, the Encore Lock features the following advancements:

Easy to install – fewer screws, fewer parts, prelocated guides and simpler side stop machining are sure to benefit the manufacturer.

Stronger – Tested to beyond DP 85 on a 36" x 72" window with only three lock points. The Encore is also rated to 400 lbs. per lock point, depending upon application.

Handle Action – Built-in detents, reduced handle to jamb contact and a tighter escutcheon means the Encore lock is more reliable and resistant to insect and light infiltration.

ADDITIONAL FEATURES & BENEFITS INCLUDE:

- Interchangeable handle and escutcheon allows homeowner to easily change the color and style of the hardware
- Escutcheon snaps into lock drive rather than into wood, producing a more secure connection.
- Locking points can be both above and below the handle for added flexibility.
- Detent in locked and unlocked positions eliminates tie bar drop in shipping and helps to pass impact testing.
- Window preparation for Encore does not require CNC machining of the stop.
- Pre-located guides on tie bars makes them easier to install.
- Single kerf locating allows use of a single screw at each guide which reduces machining and installation time and cost.
- Handed tie bar with 1 to 4 locking points.
- Available with surface mount (flange) or recessed (biscuit-style) keepers

- Stainless steel components for coastal applications are also available.
- Convert from Truth’s Mirage™ Lock to the Encore system without recertifying your window.

PRODUCT APPLICATION ASSISTANCE

If you are designing a new window profile, or are having difficulty selecting hardware for your window, please contact Truth. Our highly trained Product Specialists can assist you with the selection of the appropriate hardware to meet your performance requirements, as well as providing personalized application drawings.

CORROSION RESISTANCE

Truth’s E-Gard® Hardware has a multi-stage coating process that produces a superior physical and aesthetic finish. Plus, it is resistant to a wider range of corrosive materials, including industrial cleaning materials and environmental pollutants. This proprietary process has been tested to be approximately three times better than common zinc plated finishes. Stainless steel components for coastal applications are also available.

WARRANTY:

Protected under the terms of the Truth Warranty for Window & Door Manufacturers & Authorized Distributors. Refer to Truth’s Terms & Conditions for further details.

MATERIAL:

Molded in color plastic handle and escutcheon, Stamped steel and engineered plastic lock drive, Steel tiebar with engineered plastic guides, keepers of high strength steel or stainless steel.

FINISH:

The removable handle and escutcheon are constructed of durable, fade and scratch resistant plastic. These are supplied with color molded in for consistency with our painted products. Please refer to Truth’s Color Chart for examples of Truth’s most popular finish options.

Truth also offers a wide range of decorative “plated” finishes – contact Truth for additional information on availability of these finishes on specific product lines.



Encore Lock (locked position)



Encore Built-in Construction Handle

ORDERING INFORMATION

If application assistance is needed, please contact Truth Hardware’s Product Specialists.

1. Order Non-handed Encore™ lock drive by part number.
#12642.92 Encore lock drive assembly
2. Order Non-handed Encore Tango Sash Lock handle and escutcheon pack
#12662.XX Encore Tango handle and escutcheon (painted)
3. Specify finish number.

ENCORE™ MULTI-POINT LOCKING SYSTEM

4. Order Keepers:

#41341.92 non-handed biscuit keeper.
Or
#33593.92 (LH) and #33592.92 (RH)
flange keeper.

5. Determine tie bars required. Refer to the accompanying drawings for part numbers and standard available lengths (handing determined by hinge side when viewed from the outside).

RECOMMENDED SCREWS

Types of screw required determined by material of profile used - see Tech Note #11. Refer to drawings for complete information on screw type and quantity needed on your specific window profiles (sold separately).

TRUTH TIPS:

1. Make sure that screen stop fasteners do not interfere with the movement of the tie bar.
2. Application drawings show correct orientation of keepers to insure sequential lock-up.
3. When selecting mounting screws for Truth hardware, coating compatibility is a very important criteria. For best corrosion resistance, the material and coating on the screws should be the same as the hardware.
4. Truth recommends that a Snubber be used at the center of the hinge side on any casement window which has a tendency to bow outwardly at the center in the closed position. Adding a Snubber may increase the negative air pressure rating of the window.
5. For maximum strength, stainless steel keepers are recommended.
6. When converting from Truth's Mirage™ Lock System to the Encore Lock System, recertifying your window is not necessary. Contact Truth for more information.
7. Application of Encore Lock and Flange Keepers – Because of the self-locating features in the Encore Lock System, only one screw hole of the Lock Drive assembly needs to be pre-marked on the jamb. The locations of the Tie Bar Guides do not need to be pre-marked. The application steps are as follows:
 - A. Place the Lock Drive assembly in its locating kerf in the jamb and position it over the pre-marked hole.

B. Screw it down.

C. Move the handle to the locked position. This is necessary to correctly locate the tie bar guides.

D. Place the hook end of the Tie Bar over the mating hook on the end of the Lock Drive and place the ribs on the bottom of the Tie Bar Guides into the tie bar locating kerf in the jamb.

E. Screw down the Tie Bar Guides.

F. The Tie Bar is indexed to the Tie Bar Guides with tear away tabs. Actuate the handle to break the tie bar loose so that it can freely slide.

G. Pre-drill all screw holes in the sash for the keepers.

H. Screw down the keeper. This is easiest if the lower screw (the one under the hook part of the keeper) is applied before the upper one.

8. Application of Encore Round Top Lock and Flange Keepers – Because of the self-locating features in the Encore Lock System, only one screw hole of the Lock Drive assembly needs to be pre-marked on the jamb. The locations of the Tie Bar Guides do not need to be pre-marked. The application steps are as follows:

A. Place the Lock Drive assembly in its locating kerf in the jamb and position it over the pre-marked hole. Screw it down.

B. Move the handle to the locked position. This is necessary to correctly locate the tie bar guides.

C. Measure or calculate the length of the Connecting Link that is needed (see fig. 12). Break the connecting link to achieve the required length.

D. Bend the Round top Tie Bar to match the radius of the round top window. If the radius of the Round top Tie Bar does not closely match the radius of the window, the force to move the lock handle will increase.

E. Slide Round Top Tie Bar Guides F and G onto the Round Top Tie Bar between the roller and Connecting Link, being careful to orient them correctly.

F. Screw the Connecting Link to the ends of the straight and round top tie bars.

G. Place the hook end of the straight Tie Bar over the mating hook on the

end of the Lock Drive and place the ribs on the bottom of the Tie Bar Guides into the tie bar locating kerf in the jamb.

H. Screw down the straight Tie Bar Guides.

I. Slide Round Top Tie Bar Guide F into contact with the end of the Connecting Link and screw it down.

J. The Tie Bar is indexed to the Tie Bar Guides with tear away tabs. Actuate the handle to break the tie bar loose so that it can freely slide and then move the lock handle to the unlocked position.

K. Slide Round Top Tie Bar Guide G against the roller and screw it down.

L. Slide Round Top Tie bar Guide H onto the top end of the Round Top Tie Bar. Position the guide flush with the end of the bar and screw it down.

M. Pre-drill all screw holes in the straight portion of the sash for the keepers.

N. Move the handle to the locked position and mark the screw holes for the keeper.

O. Screw down the keepers. This is easiest if the lower screw (the one under the hook part of the keeper) is applied before the upper one.

INCLUDE TRUTH SPECS ON YOUR NEXT WINDOW PROJECT

Window locking system shall be included which will increase both security and weather seal tightness. The locking points must hold securely for negative air pressure and forced entry resistance.

The lock must incorporate a multi-point locking feature that sequentially locks the window from bottom to top. The lock must provide for a removable handle and escutcheon for ease in color changes and/or for ease in painting or staining the window. The lock shall incorporate a construction handle to allow operation of the window prior to finished hardware being applied. The locking drive and tiebar system shall be constructed of stamped steel protected with E-Gard® and high quality engineered plastics.

Window locks shall be Encore™ series, as manufactured by Truth Hardware.

FIG. 1 CASEMENT APPLICATION WITH FLANGE KEEPER

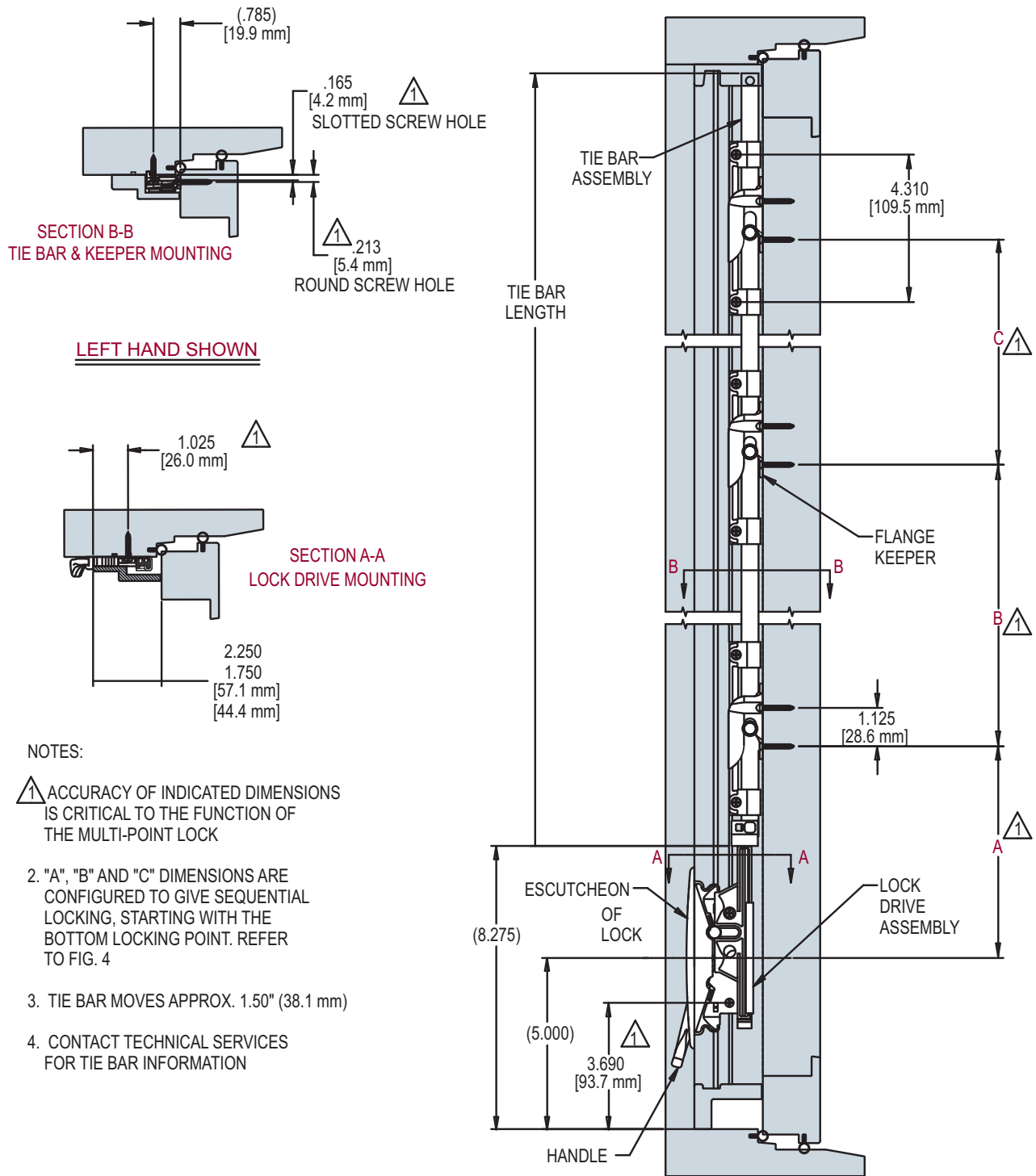

HARDWARE SHOWN	
PART NO.	DESCRIPTION
12662.XX	ENCORE TANGO HANDLE AND ESCUTCHEON
SEE FIG. 5	ENCORE TIE BAR ASSEMBLY
33593.92	STEEL KEEPER, LH FLANGE (33592.92 RH)(QTY:1 PER LOCK POINT)
12642.92	ENCORE LOCK DRIVE ASSEMBLY

ENCORE™ MULTI-POINT LOCKING SYSTEM

FIG. 2 CASEMENT APPLICATION WITH BISCUIT KEEPER

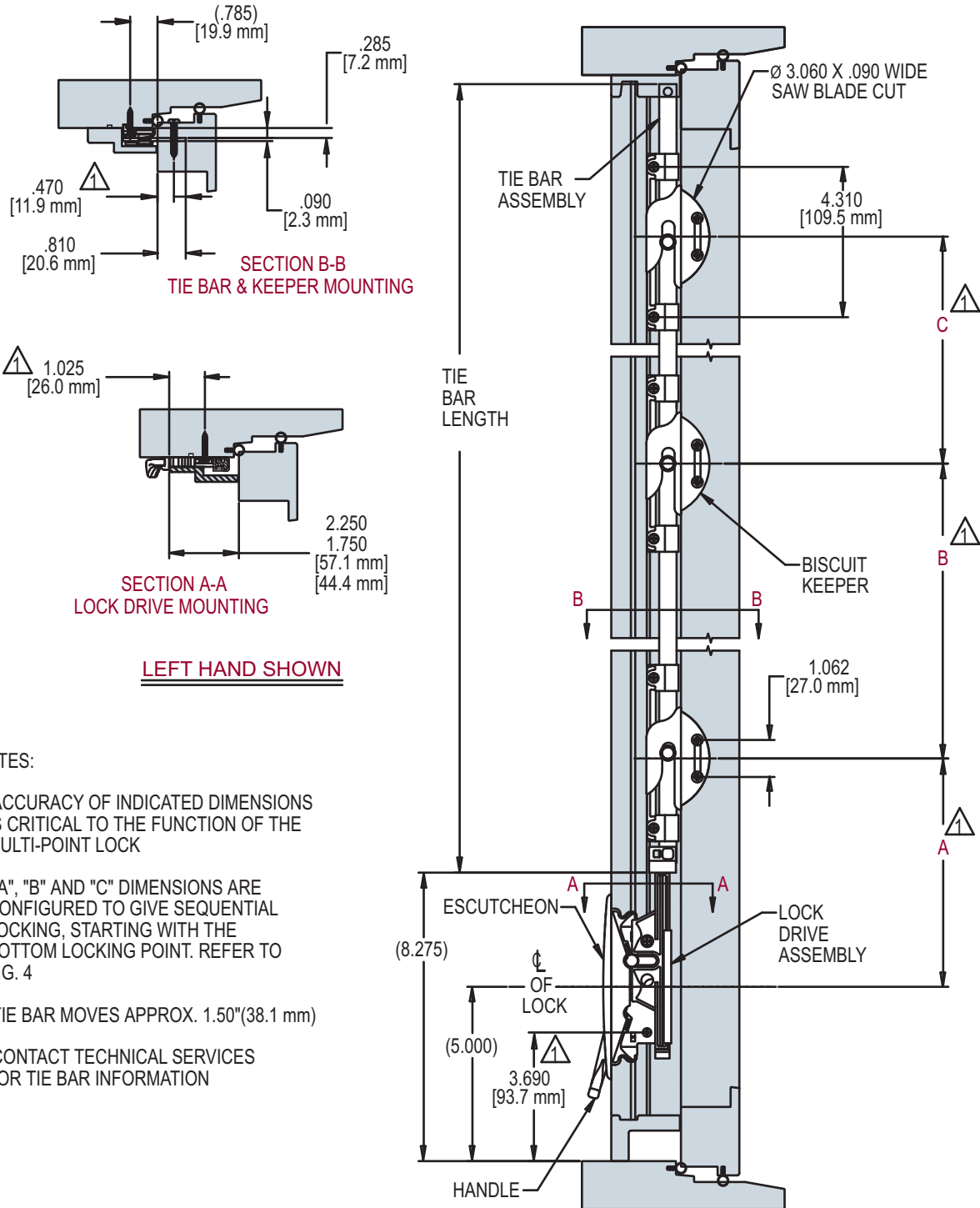

HARDWARE SHOWN	
PART NO.	DESCRIPTION
12662.XX	ENCORE TANGO HANDLE AND ESCUTCHEON
SEE FIG. 5	ENCORE TIE BAR ASSEMBLY
41341.92	STEEL KEEPER, NON-HANDED BISCUIT(QTY:1 PER LOCK POINT)
12642.92	ENCORE LOCK DRIVE ASSEMBLY

FIG. 3 TIE BARS ABOVE AND BELOW LOCK DRIVE

NUMBER OF LOCK POINTS ON UPPER TIE BAR	ADJUSTMENT TO DIMENSIONS IN FIG. 5		
	A	B	C
1	+ .310		
2	+ .155	- .155	
3	+ .100	- .050	- .050

LEFT HAND SHOWN

NOTES: 1. ADD THE ADJUSTMENTS SHOWN ABOVE TO DIMENSIONS A,B, AND C SHOWN IN FIG. 5 TO CORRECTLY SEQUENCE THE KEEPERS IN TWO TIE BAR APPLICATIONS.

2. REFER TO CASEMENT AND AWNING APPLICATIONS FOR OTHER DIMENSIONS.

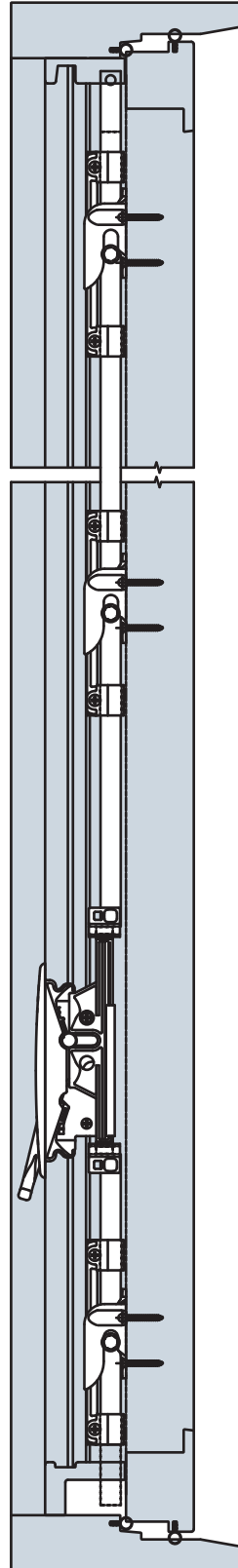

ENCORE™ MULTI-POINT LOCKING SYSTEM

FIG. 4 SIDE STOP AND JAMB ROUTING DETAIL

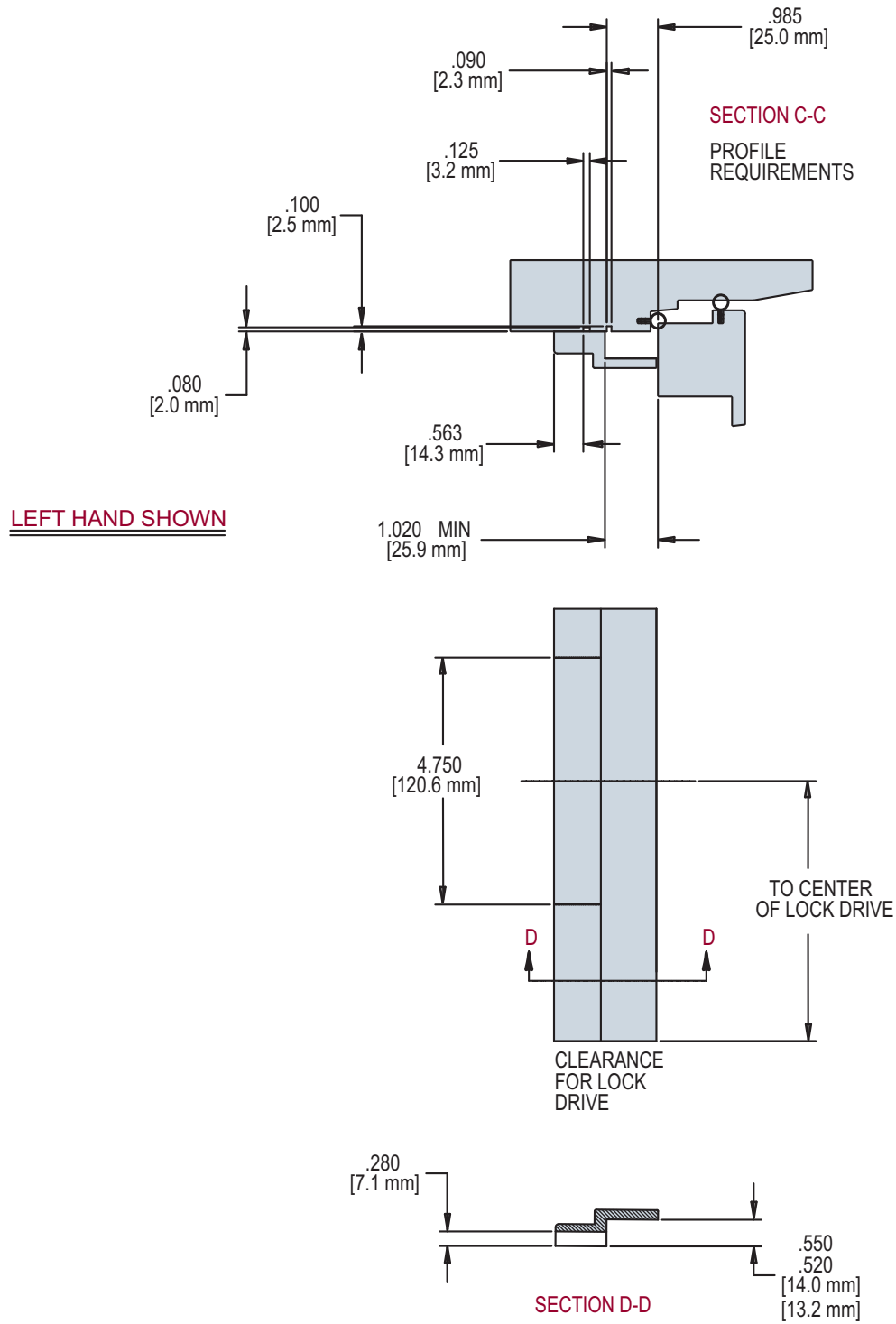
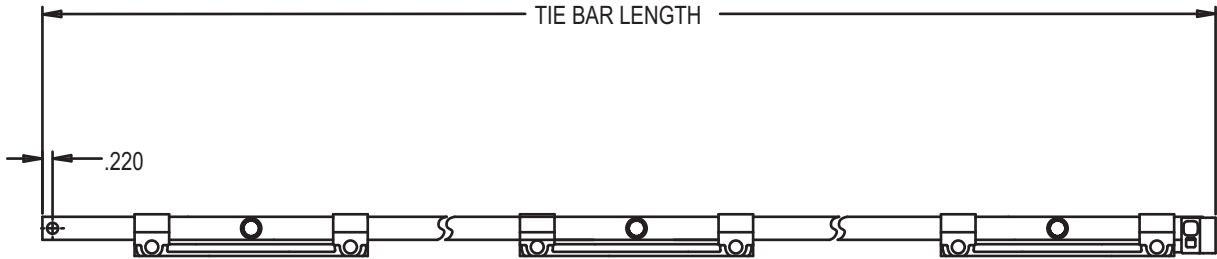

FIG. 5 TIE BAR ASSEMBLY CHART



LEFT HAND SHOWN

RECOMMENDED SCREWS

2 (P/N 19077.92)
#6 X 1 PAN HEAD
SHEET METAL SCREW

ENCORE CASEMENT TIE BAR ASSEMBLIES									
APPROX. WINDOW HEIGHT	"E" DIM ROUND TOP WINDOWS ONLY	# OF LOCK POINTS	PART NO.		TIE BAR LENGTH	"A" DIM FLANGE KEEPER \triangle	"A" DIM BISCUIT KEEPER \triangle	"B" DIM \triangle	"C" DIM \triangle
			LH	RH					
69"-75"	60"-66"	3	12659	12660	57.44	6.185	6.550	24.905	24.905
63"-69"	54"-60"	3	12657	12658	51.44			21.905	21.905
57"-63"	48"-54"	3	12696	12697	45.44			18.905	18.905
		2	12655	12656	45.44			37.810	
51"-57"	42"-48"	3	12694	12695	39.44			15.905	15.905
		2	12653	12654	39.44			31.810	
45"-51"	36"-42"	2	12651	12652	33.44			25.810	
39"-45"	30"-36"	2	12649	12650	27.44			19.810	
33"-39"	24"-30"	2	12647	12648	21.44	13.810			
27"-33"	18"-24"	1	12645	12646	15.44	13.685	14.050		
21"-27"	12"-18"	1	12643	12644	9.44	7.685	8.050		

ENCORE™ MULTI-POINT LOCKING SYSTEM

FIG. 6 AWNING APPLICATION WITH FLANGE KEEPER

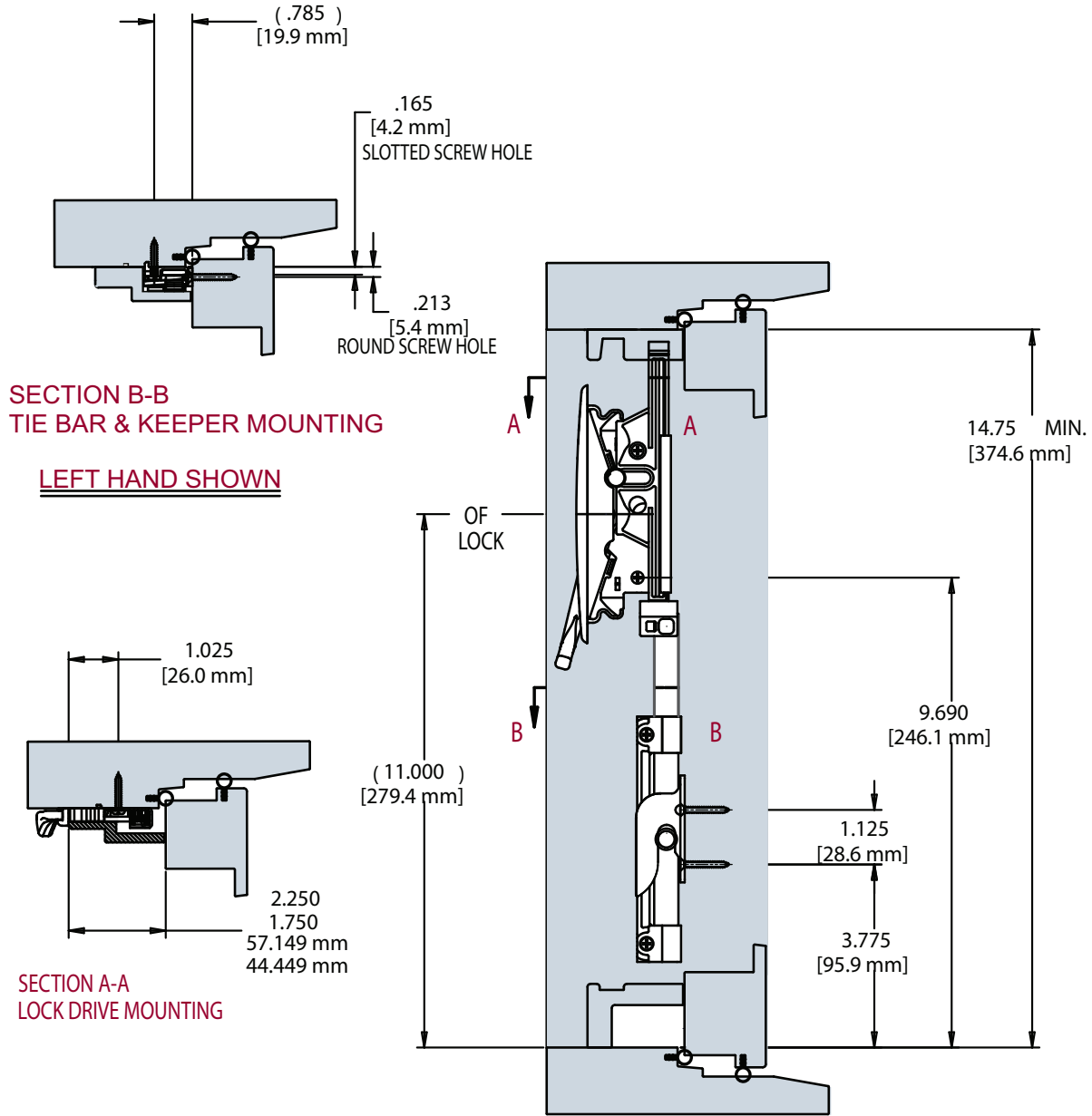

NOTES:

APPROXIMATE MINIMUM WINDOW FRAME HEIGHT IS 17.5 INCHES.

HARDWARE SHOWN	
PART NO.	DESCRIPTION
12662.XX	ENCORE TANGO HANDLE AND ESCUTCHEON
12665.92	ENCORE TIE BAR ASSEMBLY, AWNING LH (12666.92 RH)
33593.92	STEEL KEEPER, LH FLANGE (33592.92 RH)
12642.92	ENCORE LOCK DRIVE ASSEMBLY

FIG. 7 AWNING APPLICATION WITH BISCUIT KEEPER

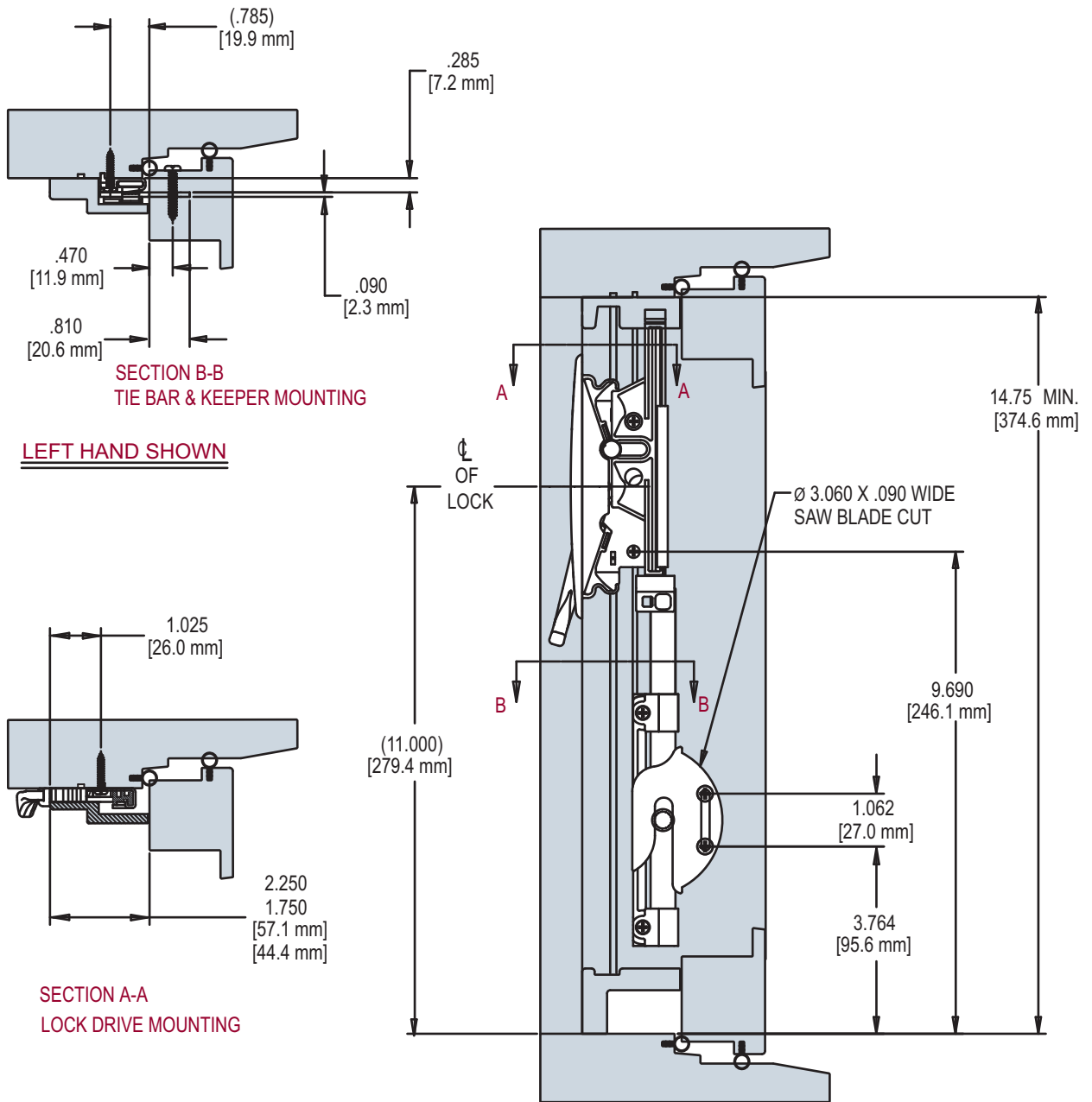

NOTES:

APPROXIMATE MINIMUM WINDOW FRAME HEIGHT IS 17.5 INCHES.

HARDWARE SHOWN	
PART NO.	DESCRIPTION
12662.XX	ENCORE TANGO HANDLE AND ESCUTCHEON
12665.92	ENCORE TIE BAR ASSEMBLY. AWNING LH (12666.92 RH)
41341.92	STEEL KEEPER, NON-HANDED BISCUIT
12642.92	ENCORE LOCK DRIVE ASSEMBLY

ENCORE™ MULTI-POINT LOCKING SYSTEM

FIG. 8 KEEPER FLANGE 33592 (RH) 33593 (LH)

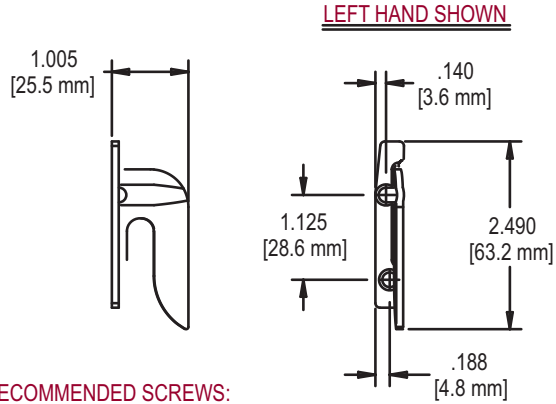

RECOMMENDED SCREWS:

2 (P/N 19051.92) #6 X 1 FLAT HEAD SHEET METAL SCREW

FIG. 9 KEEPER, BISCUIT 41341 (NON-HANDED)

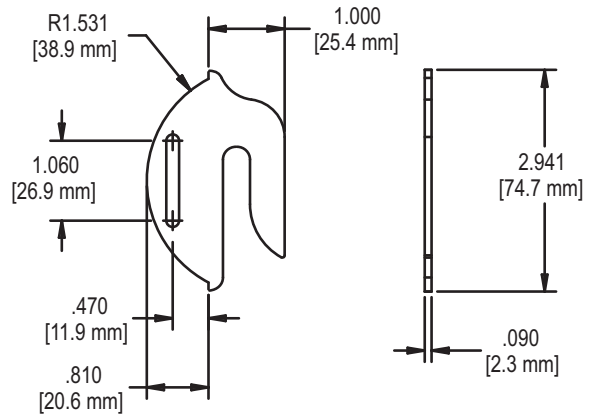

RECOMMENDED SCREWS:

2 (P/N 19230.92) #8 X 1 PAN HEAD SHEET METAL SCREW

FIG. 10 HANDLE AND ESCUTCHEON 12662.XX

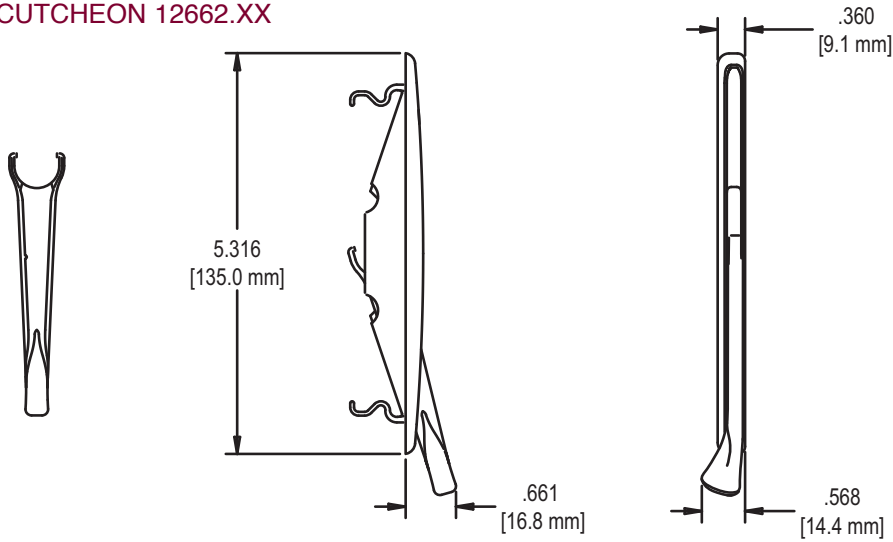
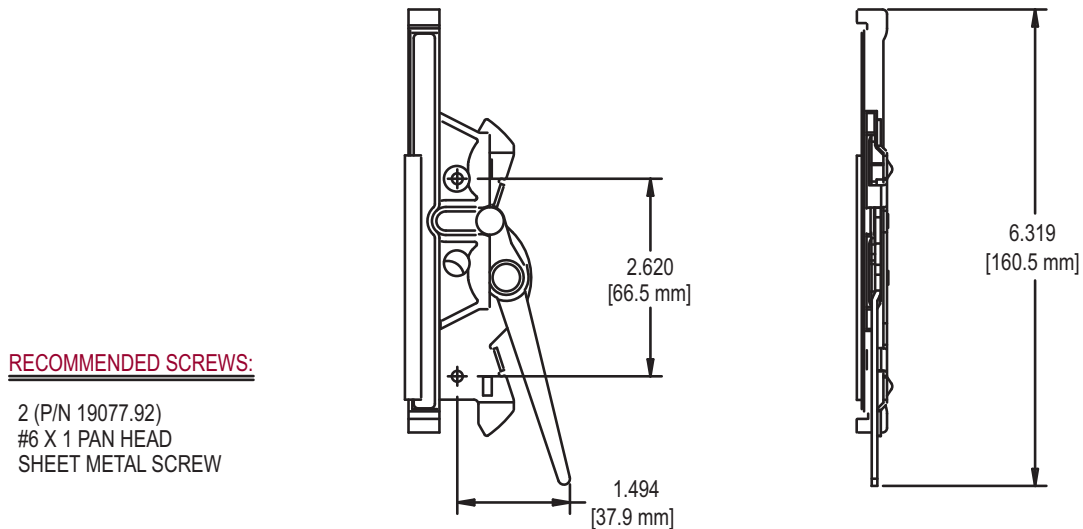

FIG. 11 LOCK DRIVE ASSEMBLY 12642.92



RECOMMENDED SCREWS:

2 (P/N 19077.92) #6 X 1 PAN HEAD SHEET METAL SCREW

FIG. 12 ROUND TOP APPLICATION

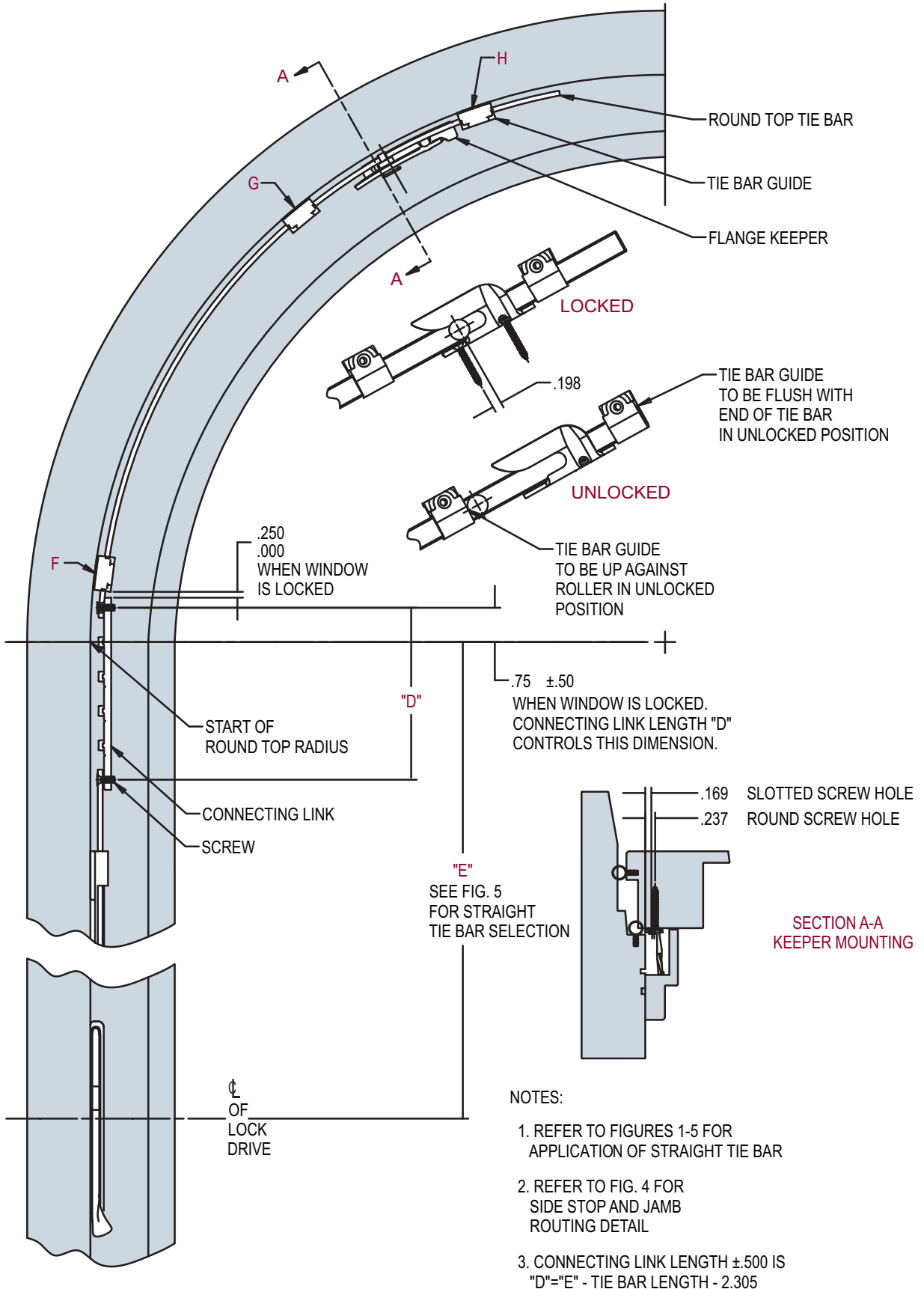

ENCORE™ MULTI-POINT LOCKING SYSTEM

FIG. 13 CONNECTING LINK 45459

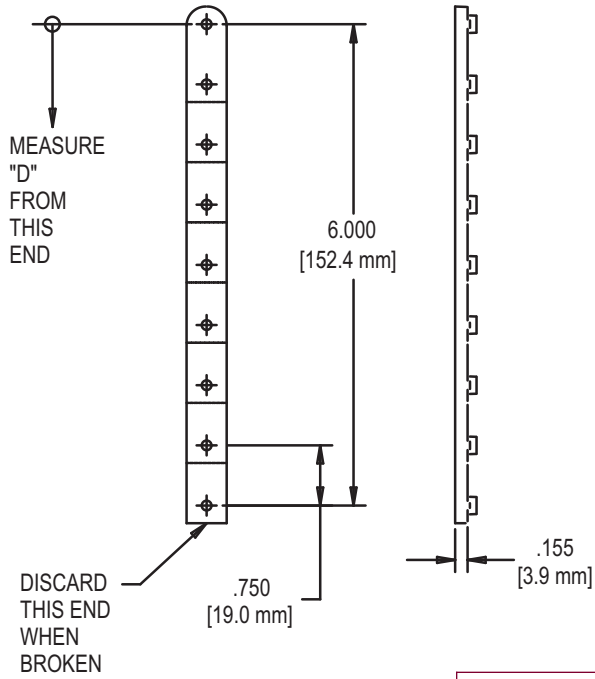

BREAK CONNECTING LINK AT APPROPRIATE "V" GROOVE TO ACHIEVE REQUIRED LENGTH

RECOMMENDED SCREWS:

(2)#6-32 X 3/8 FLAT HEAD SELF TAPPING SCREW

FIG. 14 TIE BAR GUIDE 41392

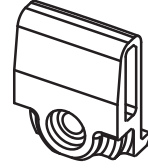

RECOMMENDED SCREW:

1 (P/N 19077.92)
#6 X 1 PAN HEAD SHEET METAL SCREW

FIG. 15 ROUNDTOP TIE BAR 12667

